



IRD-937

WDR IR Color Outdoor 3-Axis CCTV Camera (SONY Effio-e)



EXview HAD CCD II
SONY-ICX673AKA

WDR-700TVL
2.8~11mm 99°~27°

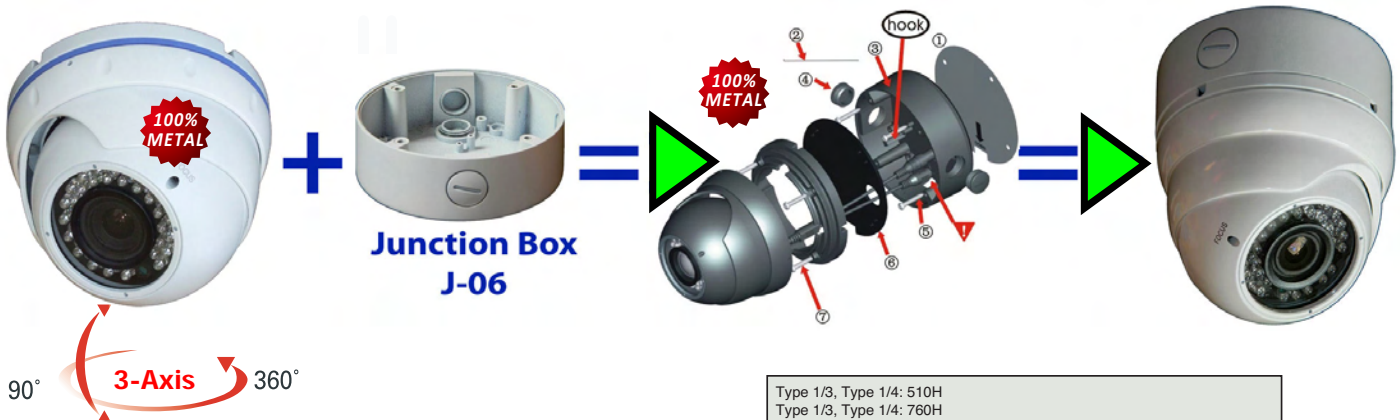

- ◆ 1/3" Digital Wide Dynamic Infrared Camera (Sony Effio-E)
- ◆ Color: 700TVL, B/W: 800TVL, 0 Lux (IR LEDs)
- ◆ Multi-Language OSD Control
- ◆ ATR Digital Powerful 128X WDR (52dB)
- ◆ Anti-Headlight (HLC), Intelligent selectable BLC
- ◆ 2D Noise Reduction, Anti-Flicker..Color Rolling suppress
- ◆ Mosaic Privacy Mask
- ◆ Advanced Motion Detection Function
- ◆ Picture Quality Adjustable (Contrast/Sharpness/Hue/Gain)
- ◆ Double Glass Lens for Avoiding Halos & Blur
- ◆ HD Aspherical Lens (f=2.8~11mm, Horiz. Angle of view: 99°~27°)
- ◆ 3-axis Cable Management Bracket & Water Resistance: IP66

- Min. Illumin.: 0.03Lux (color), -0.003Lux B/W, S/N Ratio = 52dB
- White Balance: ATW/ACR/MANUAL(1700K~11,000K)/Push&Hold/Preset
- & HLC function, Digital Zoom 16x, Day & Night function adjustable,
- Mirror function, Brightness, Contrast, Saturation, Hue
- x
- Power: 12VDC- 95mA / 370mA (IR LED on - regulated by DSP)
- IR - ILLUMINATOR 36pcs.Øx5 mm. Constant Current IR LED
- Lens adjusting from the front side
- Body Size: Ø120mmX100mm(H), 0.9Kg, 0.003m³

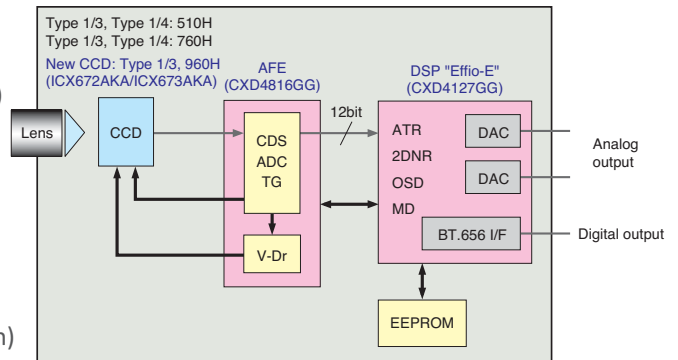

Super HAD CCD II

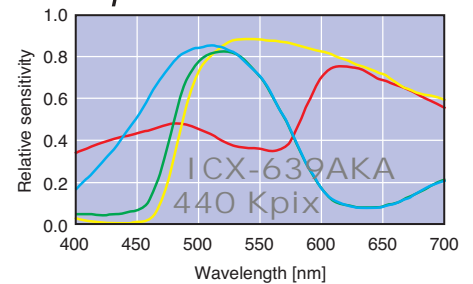

↓ +5dB

EXview HAD CCD II

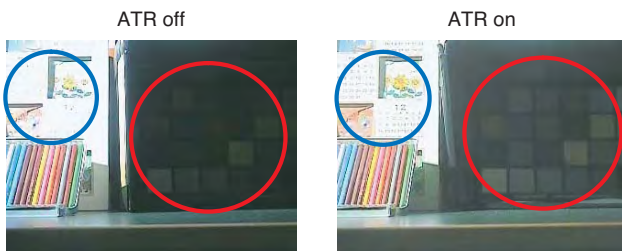
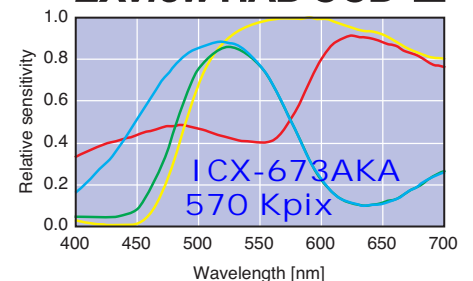

※ Specifications are approximate and subject to change without prior notice