



# IRW-942 WDR IR Color Outdoor 3-Axis CCTV Camera (SONY Effio-e)



## EXview HAD CCD II SONY-ICX673AKA

**WDR-700TVL**  
2.8~12mm 99°~24°

Cable Management Box

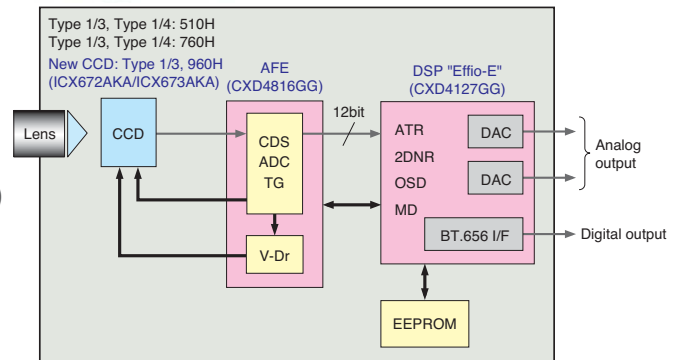

\* CCD = CCD image sensor

- ◆ 1/3" Digital Wide Dynamic Infrared Camera (Sony Effio-E)
- ◆ Color:700TVL, B/W:800TVL, 0 Lux (IR LEDs)
- ◆ Multi-Language OSD Control
- ◆ ATR Digital Powerful 128X WDR (52dB)
- ◆ Anti-Headlight (HLC), Intelligent selectable BLC
- ◆ 2D Noise Reduction, Anti-Flicker..Color Rolling suppress
- ◆ Mosaic Privacy Mask
- ◆ Advanced Motion Detection Function
- ◆ Picture Quality Adjustable (Contrast/Sharpness/Hue/Gain)
- ◆ Double Glass Lens for Avoiding Halos & Blur
- ◆ HD Aspherical Lens (f=2.8~12mm, Horiz. Angle of view: 99°~24°)
- ◆ 3-axis Cable Management Bracket & Water Resistance:IP66

- Min. Illumin.: 0.03Lux (color), -0.003Lux B/W , S/N Ratio = 52dB
- White Balance: ATW/ACR/MANUAL(1700K~11,000K)/Push&Hold/Preset & HLC function, Digital Zoom 16x, Day & Night function adjustable,
- Mirror function, Brightness, Contrast, Saturation, Hue
- With video test plug (Local Monitor) ,
- Power: 12VDC- 95mA / 480mA (IR LED on - regulated by DSP)
- IR - ILLUMINATOR 42pcs.Øx5 mm. Constant Current IR LED - adjustable
- Lens adjusting from bottom, OSD & IR Level adjust from bottom side
- Body Size:Ø84mmX140mm(L), 1.7Kg, 0.01m<sup>3</sup>

### Super HAD CCD II

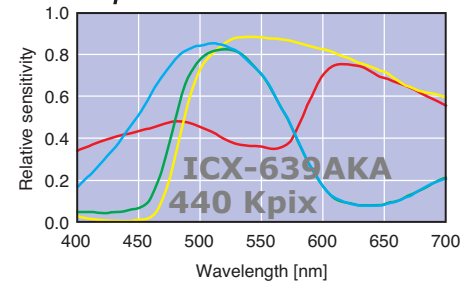

+5dB

### EXview HAD CCD II

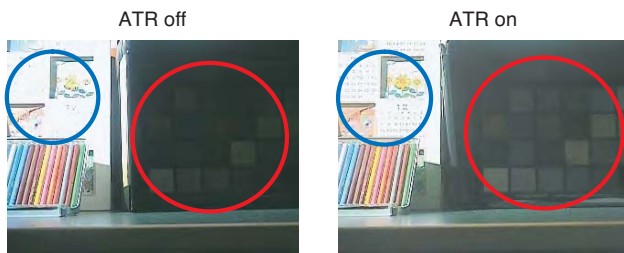
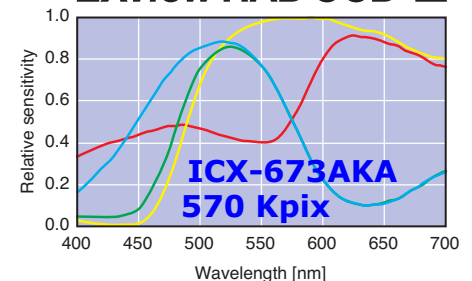

※ Specifications are approximate and subject to change without prior notice