



# IRW-936 WDR IR Color Outdoor 3-Axis CCTV Camera (SONY Effio-e)



## EXview HAD CCD II SONY-ICX673AKA



**WDR-700TVL**  
3.6mm 78°

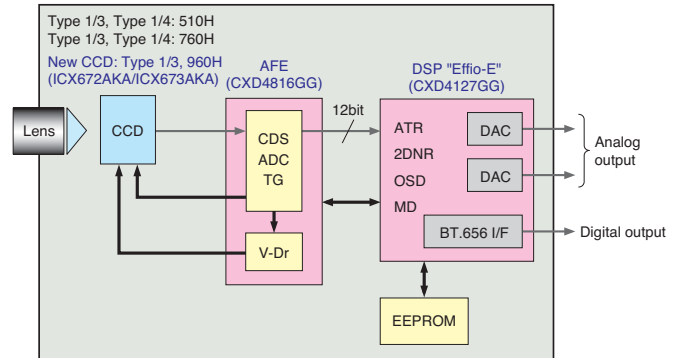

\* CCD = CCD image sensor

### Super HAD CCD II

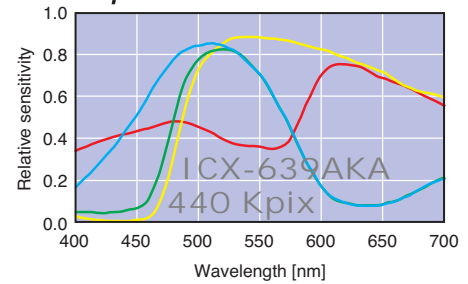

↓ +5dB

### EXview HAD CCD II

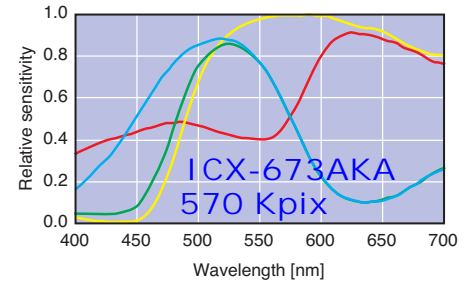

- ◆ 1/3" Digital Wide Dynamic Infrared Camera (Sony Effio-E)
- ◆ Color:700TVL, B/W:800TVL, 0 Lux (IR LEDs)
- ◆ Multi-Language OSD Control
- ◆ ATR Digital Powerful 128X WDR (52dB)
- ◆ Anti-Headlight (HLC), Intelligent selectable BLC
- ◆ 2D Noise Reduction, Anti-Flicker..Color Rolling suppress
- ◆ Mosaic Privacy Mask
- ◆ Advanced Motion Detection Function
- ◆ Picture Quality Adjustable (Contrast/Sharpness/Hue/Gain)
- ◆ Double Glass Lens for Avoiding Halos & Blur
- ◆ HD Aspherical Lens (f=3.6mm, Horiz. Angle of view: 78°)
- ◆ 3-axis Cable Management Bracket & Water Resistance:IP66
- Min. Illumin.: 0.03Lux (color), -0.003Lux B/W, S/N Ratio = 52dB
- White Balance: ATW/ACR/MANUAL(1700K~11,000K)/Push&Hold/Preset & HLC function, Digital Zoom 16x, Day & Night function adjustable,
- Mirror function, Brightness, Contrast, Saturation, Hue
- Power: 12VDC- 95mA / 380mA (IR LED on - regulated by DSP)
- IR - ILLUMINATOR 36pcs.Øx5 mm. Constant Current IR LED - adjustable
- Body Size:84mmX140mm(L), 0.57Kg, 0.0028m<sup>3</sup>

⌘ Specifications are approximate and subject to change without prior notice